

# Carroll County Western Circuit Rule Book

## Constitution Article I

### **Section 1. TITLE:**

This association shall be known as the "Carroll County Western Circuit", and shall at all times be operated as a non-profit Association in accordance with the laws of the State of Maryland.

### **Section 2. OBJECTIVE:**

The purpose of the Association shall be to:

- A. Coordinate shows dates.
- B. Promote and/or conduct English/Western horse/pony shows, clinics and trail rides.
- C. To stimulate and regulate any and all matters such as may pertain to the Carroll County Western Circuit.
- D. To work in the interest of and for the improvement of horse/pony activities in Carroll County and the State of Maryland.

### **Section 3. PLACE OF BUSINESS:**

The principle place of business shall be in Carroll County, Maryland, but business may be carried on at any place convenient to such member of officers, as may be participating.

## Article II

### **Section 1.**

This association is open to organizational groups sponsoring English/Western horse/pony shows, clinics and trail rides.

### **Section 2.**

Application for membership in the Carroll County Western Circuit shall be filed with Association Secretary. The Executive Committee will set dues. An annual fee of \$10.00 for individuals, and \$20.00 for families (families must be immediate or resident members of the family home) shall be paid for each annual membership. This fee shall be due and payable each year. Notice to the member of fees payable shall be sent to members at their last known address not less than 30 days prior to the end of the calendar year, which is March. When annual membership becomes delinquent, paying the current dues can reinstate the membership. Annual membership is not transferable.

### **Section 3.**

Membership in the Association is a privilege, not a right. Application for which shall be made on forms and by fees and procedures prescribed from time to time by the Association. Membership or application thereof may be terminated or rejected by the Executive Committee for cause detrimental to the interest of the Association, its programs, policies, objectives and harmonious relationships to its members.

### **Section 4.**

All officers must attend all board meetings. If any vacancies are incurred during the year, the Executive Committee will fill the vacancy.

### **Section 5.**

Should a question arise that is not covered by the rules, it will be referred to the Executive Committee whose decision is final.

## Article III

### **Section 1.**

In the event the Association should fail to meet the obligations of its by-laws, all money will be turned over, by check to the Carroll Hospital Center, in Westminster, Maryland.

### **Section 2.**

The Executive Committee must approve dissolution of the Carroll County Western Circuit in writing.

**Section 3.**

All assets will be held for thirty (30) days after notification of the organization and individual members of the proposed dissolution of the Circuit pending rebuttal by any member, organization or individual.

**BY-LAWS**

**Article I**

**Section 1.**

The business and property of the Circuit shall be managed and controlled by the Executive Committee.

**Section 2.**

The Executive Committee will consist of ALL elected officers.

**Section 3.**

Special meetings of the Executive Committee shall be held whenever called by the direction of the President.

**Section 4.**

The Executive Committee has the right to refuse those entries who have been unsportsmanlike in conduct, or who have cast aspersions on any member of this Circuit at previous horse/pony shows of an organization, of any circuit or have unpaid debts to this circuit, upon approval by the officers.

**Article II**

**Section 1. OFFICERS**

The officers shall be elected at the October meeting by the members in good standing of the Carroll County Western Circuit no less than 90 days and no less than the age of 18 years. These officers will assume their positions at the December meeting.

**Section 2. PRESIDENT**

The President shall be the chief executive officer of the Association and shall preside at all meetings. He/She shall see that the by-laws, rules and regulations of the Association are enforced and shall perform all other duties that may be prescribed from time to time. He/She shall appoint all committees except as provided in the by-laws.

**Section 3. VICE PRESIDENT**

In the absence of the President, the Vice President shall have the powers and shall perform the duties of the President.

**Section 4. SECRETARY**

The Secretary shall keep the minutes of all membership meetings, confirm show dates and advise on conflicting dates, mail minutes to the members and be responsible for records.

**Section 5. TREASURER**

The Treasurer shall receive and deposit all monies of the Circuit. The money will be disbursed only upon an itemized statement or receipt. He/she shall account for all of the same by itemized statements in detail at each annual meeting of the members. All checks issued by CCWC will require two (2) signatures by the President, Vice President, Secretary, Treasurer or Director, or any combination thereof.

**Section 6. CHIEF RING STEWARD**

The Chief Ring Steward will be responsible for seeing that all the rules of the Circuit in all Divisions will be adhered to and to report to the President.

**Section 7. DIRECTORS**

The Directors will take any suggestions, compliments, complaints, etc. and share them with the other board members at the monthly meeting.

## Section 8. POINT STEWARD

The Point Steward will keep and update all show points and records and point sign ups. **Points will be posted at each show.**

## SHOW AND CONTEST RULES AND REGULATIONS

These rules and regulations shall become effective 3/17/2011 and shall be used at all approved shows and contents of the Carroll County Western Circuit.

### RULE A. MEMBERSHIP

Individual \$10.00

Family \$20.00

### RULE B COGGINS TEST

Effective November 1, 1975

A regulation went into effect which states that all horses over the age of 9 months assembled for horse shows shall be accompanied by a copy of an official negative test for Equine Infectious Anemia (Coggins Test) made within 12 months of the date of the event for the club to keep on file. All members must provide CCWC with a copy of their horse's coggins to keep on file for the entire show season.

### RULE C POINT REGISTRATION OF HORSE/PONY

Application for registration of points must be made by a CCWC member in good standing. Registration fee will be \$6.00 per horse/rider team to entitle them for points in all pointed classes and a permanent number. Exhibitors assume responsibility for showing in proper entry number based on horse/rider combination. Failure to do so will result in disqualification.

### RULE D JUDGES

1. A judge **may not** officiate in any shows in which a member of his family, any of his/her clients, or any of his/her horses, are competing unless relationship terminated six months prior to said show.
2. A judge may order any person or horse from the competition for bad conduct of one or both.
3. All judge's decisions are final.
4. Any act of disobedience or discourtesy to a Judge or a Steward by any person shall constitute a violation.
5. Once a class has been judged, it shall not be re-judged; and once the Judge has marked his records and placing for awards made, there shall be no changing of the Judge's records except for mathematical errors.
6. **Any request to speak to the Judge must be made through the Ring Steward.** When an exhibitor makes a request, it is urged that the Judge, in the presence of the Ring Steward, give his opinion in a courteous and sincere manner. **However there will be no fraternization between the exhibitor and the Judge during the show.**
7. All Judges' cards will be provided by CCWC and must be signed by the Judge.

### RULE E EQUIPMENT AND ATTIRE

1. It is mandatory that show management supply exhibitors with entry numbers. Failure by the exhibitor to wear the number in a visible manner shall result in disqualification. Exhibitors assume responsibility for showing in the proper entry number based on horse/rider combination. Failure to do so will result in disqualification.
2. **Protective headgear (ASTM/SEI approved helmet) with a fixed harness MUST be worn by all riders 17 & under at all times when mounted or riding. Hunting Cap of any type is mandatory for all pleasure riders over the age of 18 in all-flat classes. THIS RULE WILL BE ENFORCED.**
3. **Western Attire** shall include:
  - a. **Pleasure:** pants (slacks, trousers, jeans, etc.), long sleeved shirt with collar (band, stand-up, tuxedo, etc), western hat/helmet (youth 17 & under) and cowboy

boots. Jackets and sweaters acceptable. Spurs and chaps are optional.  
**Protective headgear (ASTM/SEI approved helmet) with a fixed harness MUST be worn by all riders 17 & under at all times when mounted or riding.**

- b. **Speed:** long or short sleeved shirt with collar, western hat/helmet (youth 17 & under) or no hat at all. **Protective headgear (ASTM/SEI approved helmet) with a fixed harness MUST be worn by all riders 17 & under at all times when mounted or riding.** No baseball caps, T-shirts or tank tops are permissible in any event. Tapederos allowed only in Leadline divisions. Tie downs are optional; however, jerk lines and tack collars are prohibited.
4. **English Attire** shall include coat, breeches, with tall English boots or jodhpur pants with jodhpur boots. Stock tie or choker is required. Spurs of the unrowelled type, crops, or bats are optional. No schooling chaps permitted. Hair must be neat and contained (net or braid). Standing or running Martingales, boots and leg wraps in jumping only. Hunting Cap of any type is mandatory for all pleasure riders over the age 18 in all-flat classes. **Protective headgear (ASTM/SEI approved helmet) with a fixed harness MUST be worn by all riders 17 & under at all times when mounted or riding. Hunting Cap of any type is mandatory for all pleasure riders over the age of 18 in all-flat classes. THIS RULE WILL BE ENFORCED.**
5. Parent/Handler in all Leadline classes must be dressed appropriately. No sneakers, open-toed shoes, baseball caps, T-shirts, tank tops or shorts are permissible.
6. The judge may penalize an exhibitor who does not conform to the rules for proper attire.

#### **RULE F            TIMERS**

Equipment timers will be used in speed events along with a stopwatch. In the event the timers fail, the time from the stopwatch will be the official time. The Judge will not judge timed events. All exhibitors **in timed events who are age 17 & under must wear an ASTM/SEI approved helmet with a fixed harness.**

#### **RULE G            EXHIBITORS**

1. It is the responsibility of the exhibitor to be ready and at ringside when his/her class is called.
2. Any exhibitor who sets or incites to act in a manner deemed dishonest, unsportsmanlike, or unethical shall be subject to barring by the Executive Committee.
3. No one will be allowed in the show-ring once the class has started and there will be no additional sign-ups. **Sign-Ups must be completed at least two (2) classes prior to the one you are signing up for. Entries will close on class prior to the current class.**
4. **NO REFUNDS.**

#### **RULE H            CRUELTY**

Cruelty or abuse to a horse/pony by any person is in violation of the rules and renders the offender subject to a penalty. The offender will be barred from further participation for the remainder of the show. All entry fees will be forfeited. The Judge will enforce the rule in the ring and the Stewards will enforce the rule outside the ring.

#### **RULE I            DIVISIONS**

For horse show purposes, the age of an individual as of January 1<sup>st</sup> shall be maintained throughout the entire year. Proof of age (copy of birth certificate, or driver's license) must be handed in for all exhibitors 17 years or younger before being eligible to accumulate points.

##### **Age Groups:**

Leadline & Speed	9 & Under
A, A W/T, Adult Novice	18 & Over
B & B W/T	17 & Under
Y (W/T/L and W/T/C)	13 & Under
W/T	13 & Under

**Class Divisions:**

Mini Horse  
Lead Line  
Western A  
Western B  
Western Y  
Western W/J  
Adult Novice  
English A  
English B  
English Y  
English W/T  
Leadline Speed  
Speed W/T A  
Speed W/T B  
Speed A  
Speed B  
Speed Y  
Green Horse Western  
Green Horse English

Anyone wishing to move forward to the next age division may do so, however, once done, may not return to their previous age division.

**RULE J PROTESTS**

1. A protest must be made within one (1) hour of the alleged violation by one individual with a \$50.00 deposit to the Chief Steward and will be announced to all exhibitors.
2. All ribbons and prize money must be returned to the Steward until the protest has been resolved. If the protest is sustained, the deposit shall be returned to the protestor; if not sustained, the deposit shall be forfeited to the Carroll County Western Circuit.
3. The Judge or Ring Steward's decision is final unless it is alleged to be in violation of the rules. The soundness of a horse when determined by a judge is not protestable unless a veterinarian is present.

**RULE K TIES**

1. **Ties for English and Western** classes will be at the discretion of the Judge. The Horsemanship/Equitation pattern will be used for that day. The Judge will decide if you ride off or take placing for the day.
2. **Speed** ties will be run with the last class standing or TBA at that time.
3. **Year End** Ties will be the last show placings; i.e. most blues or reds.

**RULE L SUBSTITUTION OF HORSE/PONY**

No substitutions of horses/ponies will be made with the exception of Leadline, Horsemanship and Showmanship classes where the points stay with the person rather than the horse/pony. Substitutions in any division for health reasons will be accepted with a valid veterinarian certificate.

## **RULE M            AWARDS**

1. Grand Champion and Reserve Champion will be given out in the following divisions at each show. Points will be determined with a horse/exhibitor combination only.

### **Class Divisions:**

Mini Horse  
Lead Line  
Western A  
Western B  
Western Y  
Western W/J  
Adult Novice  
English A  
English B  
English Y  
English W/T  
Leadline Speed  
Speed W/T A  
Speed W/T B  
Speed A  
Speed B  
Speed Y  
Green Horse Western  
Green Horse English

2. Year End Awards will be given out in the following divisions. Points will be determined with a horse/exhibitor combination only.

### **Class Divisions:**

Mini Horse  
Lead Line  
Western A  
Western B  
Western Y  
Western W/J  
Adult Novice  
English A  
English B  
English Y  
English W/T  
Leadline Speed  
Speed W/T A  
Speed W/T B  
Speed A  
Speed B  
Speed Y  
Green Horse Western  
Green Horse English

3. Exhibitors 18 & over MUST attend 5 of the 6 shows in order to qualify for year-end awards. Exhibitors 17 & Under MUST attend 50% of shows and complete two (2) hours of volunteer service time for Carroll County Western Circuit to qualify for year-end awards. Volunteer hours must be completed by the end of the show season. Service time is available on a first come first serve basis. Forms will be available at the entry booth. If your horse is ill or unsound and you help at a show, your points will still count. You must talk to a board member the morning of the show.

#### **RULE N POINTS / MONEY AWARDS**

1. Points are as follows: First Place 6pts; Second Place 5pts; Third Place 4 pts; Fourth Place 3 pts; Fifth Place 2 pts; Sixth Place 1 pt.
2. All pointed classes with 12 or more Exhibitors will be a payback class. Paybacks are as follows: **Top four placings**; First Place \$8.00, Second Place \$6.00; Third Place \$4.00 Fourth Place \$2.00.
3. Points will be posted at shows periodically throughout the season and the exhibitor has the responsibility of checking his/her point standings. Points will be tallied on a horse/rider combination only.
4. Exhibitors 18 & over **MUST** attend 5 of the 6 shows in order to qualify for year end points.
5. Exhibitors 17 & Under must attend 50% of shows and complete two (2) hours of volunteer service time for Carroll County Western Circuit to qualify for year end points.

#### **RULE O MINI HORSE CLASSES**

1. **Attire:** Drivers should be dressed in appropriated dress to compliment the overall appearance of the unit. Hat, long sleeves and boots required (no t-shirts or shorts).
2. Mini Horse Showmanship: This class is judged on the exhibitor's ability to fit and show in a halter class. A pattern will be required at the Judges' discretion. Show the horse to his/her advantage and keep showing until the class is dismissed.
3. Mini Horse Halter: This class is for Mini Horses with a maximum height of 38 inches. Horses will be led at a walk and jog. If all conformation factors are the same, judging preference will go to the smaller horse. Show the horse to his/her advantage and keep showing until the class is dismissed.
4. Mini Horse Trail: The Mini Horse will be led over obstacles. The horse may be asked to walk and jog. Performance is judged over obstacles & response to handler and intelligence.
5. Mini Driving Class: Dress Code: Drivers should be dressed in appropriated dress to compliment the overall appearance of the unit. Hat, long sleeves, and boots required (no t-shirts or shorts). Whips, leg wraps, side-/over-checks, breeching and martingales are optional. Any type of cart and harness may be used. Horses should never be left unattended while hitched to a vehicle. Youth exhibitors may drive with an adult passenger (over 18) but the passenger is only there for safety and emergency situations. Passenger must be appropriately dresses in hat, long sleeves and boots. All driving horses shall show on the rail at all times except while passing (on the inside of the circle). Exhibitor numbers must be pinned to the back of the driver. It is permissible for the driver to talk to the horse in a subdued tone of voice. Talking loud, whistling, or shouting at a horse is not acceptable. **Ring Procedure:** Horses are to enter the ring counter-clockwise (to the right) at a pleasure trot. To be shown both ways of the arena at a walk, pleasure trot and extended trot. **Walk:** a free regular and forward moving 4 beat gait. The horse walks energetically, but calmly, with even and determined gait. **Pleasure Trot:** A balanced, easy moving, relaxed, forward impulsion while showing submission to the bit. The trot is slower and more collected, but the horse should indicate willingness to be driven on the bit while maintaining a steady cadence. **Extended Trot:** a clear, but not excessive, increase in gait and length of stride. The horse moves freely on a taut but light rein, while maintaining a balanced gait and forward movement. Excessive knee action and speed shall be penalized. **Reverse Direction:** The judge will point to the driver that's at the corner of the ring (not along the sides in the middle) and that person must come across the center (like a figure "S") and change direction. Everyone behind this driver is to follow the leader in order to keep the ring flowing without any collisions. **Line Up:** Horses must display good manners, stand quietly on the line-up and back readily. A pattern will be posted for the Obstacle Class.

#### **RULE P LEADLINE SPEED DIVISIONS**

1. **Attire:** See **RULE E: Equipment and Attire**
2. Points are accumulated on the rider only.
3. The exhibitor will be timed.
4. The person leading the child into the ring must be at least fifteen (15) years of age.

5. Parent/Handler must stay at horses shoulder when crossing the Start/Finish line.
6. **Leadline Detached Plug Walk:** To be shown without Leadline at a walk. Parent/Handler may stand beside the horse/pony. Horse/pony to be judged the same as Leadline.
7. The Leadline division will consist of the following classes for year-end awards: Barrels, Figure 8, Plug and Leadline Detached Plug Walk.

#### **RULE Q            SPEED DIVISION (TIMED EVENTS)**

1. **Attire:** See **RULE E: Equipment and Attire**
2. Horses must leave the ring in a controlled manner. Speed event patterns will be measured and altered to fit the ring being used. The Ring Steward may prohibit the use of bits or equipment he/she considers severe. In the event there is no starting gate, cones will be used. Adequate room will be provided. Riders must start and finish through the cones for qualifying times.
3. **Walk/Trot Classes:** Horse must remain at a walk/jog/trot during the entire pattern. If the horse breaks into a lope or canter, the rider has three (3) strides to bring the horse back down to a walk/jog/trot or else the horse will be disqualified. Gaited horses must hold a two (2) beat trot at all times.
4. **Barrel Race:** The horse may take either of the side barrels first. If the right is chosen, it must be circled clockwise and the second and third barrels must be circled counter-clockwise. If the left barrel is chosen, it must be circled counter-clockwise and the second and third barrels clockwise. A horse knocking over a barrel will result in five (5) second penalty. Cloverleaf pattern.
5. **Figure 8 Race:** Two Barrels or stakes will be set in a straight line eighty (80) feet apart. On a right-sided pattern, the rider will begin behind the Start/Finish line, run down to the second barrel, turn counter-clockwise, cross through the center, make a clockwise turn around first barrel, cross through center, make a counter-clockwise turn at second barrel, and run straight to the Start/Finish line. Rider can start on left side but must reverse pattern. Rider must complete a figure 8. Knocking down a barrel or stake will result in a five (5) second penalty.
6. **Plug:** Horses will run down and turn the barrel and run back across the finish line. Knocking down barrel will result in a five (5) second penalty.
7. **Four (4) Corner Stake Race:** Four (4) Standing Poles will be used set seventy-five (75) feet apart in a square. On a right sided pattern, horse will go to first pole on right side, make clockwise turn, go straight across ring, make a counter-clockwise turn as in barrels, then go to far right pole, make another clockwise turn, go straight across to fourth pole, make clockwise turn, run straight through center to Finish line. Must stay between poles. Knocking down a pole will result in a five (5) second penalty.
8. **Poles:** Six (6) Standing Poles set twenty-one (21) feet apart in a straight line. Horse will run to the farthest most pole, weave down and back and run towards the finish line. Knocking down a pole will result in a five (5) second penalty.
9. **Bleeding Heart:** Set up same distance as Barrels, Horse will run to either left or right Barrel go to the outside of the furthest Barrel turn to the center of the ring run to the middle barrel turning to the outside of that Barrel and run to the next farthest Barrel turning to the outside and head for the Finish line. Knocking down a barrel will result in a five (5) second penalty.
10. **Texas Barrels:** Barrels are set up three (3) barrels in a row at thirty feet (30') apart. Enter ring and start on either left or right side of the barrel, then weaving each barrel and turning and weaving each barrel heading for the start line. Knocked down barrel will result in a five (5) second penalty.
11. **Grow as You Go:** See Versatility Patterns in Attachment A
12. **Tie-Score Race:** See Versatility Patterns in Attachment A
13. **Pick-A-Lock:** See Versatility Patterns in Attachment A
14. Versatility Patterns are depicted in Attachment A.

#### **RULE R            LEADLINE DIVISION**

1. **Attire:** See **RULE E: Equipment and Attire**

2. Points are accumulated on the rider only.
3. **Leadline 9 & Under E/W:** To be shown on loose leadline at a walk. Horse/pony to be judged 50% on suitability to the rider and 50% on hands and seat of rider. Permanent number stays with the rider.
4. **Leadline Detached 9 & Under E/W:** To be shown without leadline at a walk. Parent/Handler may stand beside the horse/pony. Horse/pony to be judged the same as Leadline.
5. **Leadline Detached Horsemanship Walk 9 & Under E/W:** To be shown without leadline at a walk. Parent/Handler may stand beside the horse/pony. Pattern will be required.

#### **RULE S ADULT NOVICE DIVISION**

1. Attire: See RULE E: Equipment and Attire
2. Open only to beginner or non-experienced show riders over the age of 18. Along with specified novice classes, novice riders can show in the following classes: Showmanship and all Halter Classes. Experience clarification will be determined by the Executive Committee.
3. The year end High Point Champion must move to the A Division the following year. Anyone wishing to move forward out of the novice division may do so, however, once done, one may not return to the novice division.
4. All classes are a combination of Western and English.
5. **Adult Novice Showmanship:** This class shall be judged strictly on the exhibitor's ability to fit and show in a halter class. A pattern may be required at the discretion of the judge.
6. **Adult Novice Trail:** See Western Trail Class. To be shown at a walk, jog/trot.
7. **Adult Novice All Day W/T/J:** See All Day Western W/J or All Day English W/T
8. **Adult Novice Pleasure:** See Western or English Pleasure. To be shown at a Walk/Jog/Lope or Walk/Trot/Canter.
9. **Adult Novice Horsemanship/Equitation W/T/J:** See Horsemanship or Equitation. To be shown at a Walk/Jog/Trot.

#### **RULE T GREEN HORSE DIVISION (WESTERN)**

1. Attire: See RULE E: Equipment and Attire
2. 1st and 2nd Year Green Horse - Open to horses, regardless of horse's age, that have not shown anywhere. Horses are ineligible after their second year of showing.
3. Green horses may cross enter into aged divisions. Must maintain Green Horse equipment in all classes.
4. No shank bits are permitted in Green Horse classes. Two hands are required.
5. **Green Horse Trail:** Classes will be judged on the performance of the horse at two gaits, performance over obstacles, and response to the rider.
6. **Green Horse Western W/J:** Class to be judged on the horse both ways of the ring at the walk and jog. May be asked to back.
7. **Green Horse Western W/J/L:** Class will be judge on the performance and conformation of the horse at the discretion of the judge. Entries will be penalized for incorrect gait or being on the wrong lead. Horses will be judged at a walk, jog and lope on reasonably loose rein both ways of the ring. Horses will be reversed to the inside and will be required to back.

#### **RULE U GREEN HORSE DIVISION (ENGLISH)**

1. Attire: See RULE E: Equipment and Attire
2. 1st and 2nd Year Green Horse - Open to horses, regardless of horse's age, that have not shown anywhere. Horses are ineligible after their second year of showing.
3. Green horses may cross enter into aged divisions. Must maintain Green Horse equipment in all classes.
4. No shank bits are permitted in Green Horse classes. Two hands are required.
5. **Green Horse English W/T:** Class to be judged on the horse both ways of the ring at the walk and trot. May be asked to back. The smoothness, willingness and consistency of the performance will be considered.



- iii. When using a romal, no fingers between the reins are allowed. The free hand may not be used to adjust the rider's length of rein in any reining class.
    - iv. During reining, the use of the free hand while holding the romal to alter the tension or length of the reins from the bridle to the reining hand is considered to be the use of two hands and a score of 0 will be applied, with the exception of any place a horse is allowed to be completely stopped during a pattern.
    - v. In all other classes, including the reined portion of working cow horse, the free hand may be used to adjust the rider's length of rein.
  - d. Failure to complete pattern as written:
  - e. Performing the maneuvers other than in specified order;
  - f. The inclusion of maneuvers not specified, including, but not limited to
    - i. Backing more than 2 strides
    - ii. Turning more than 90 degrees
  - g. Equipment failure that delays completion of pattern; including dropping a rein that contacts the ground while horse is in motion.
  - h. Balking or refusal of command where performance is delayed;
  - i. Running away or failing to guide where it becomes impossible to discern whether the entry is on pattern;
  - j. Jogging in excess of one-half circle or one-half the length of the arena;
  - k. Overspins of more than 1/4 turn;
  - l. Fall to the ground by horse or rider Neither a No Score nor a 0 are eligible to place in a go round or class, but a 0 may advance in a multi-go event while a no score may not.
9. The following will result in a reduction of five points:
- a. Spurring in front of cinch;
  - b. Use of either hand to instill fear or praise;
  - c. Holding saddle with either hand;
  - d. Blatant disobediences including kicking, biting, bucking, rearing and striking.
10. The following will result in a reduction of two points:
- a. Break of gait;
  - b. Freeze up in spins or rollbacks;
  - c. On walk-in patterns, failure to stop or walk before executing a canter departure.
  - d. On run-in patterns, failure to be in a canter prior to the first marker.
  - e. If a horse does not completely pass the specified marker before initiating a stop position.
11. Starting or performing circles or eights out of lead will be judged as follows: Each time a horse is out of lead, a judge is required to deduct one point. The penalty for being out of lead is accumulative and the judge will deduct one penalty point for each quarter of the circumference of a circle or any part thereof that a horse is out of lead. A judge is required to penalize a horse one-half point for a delayed change of lead by one stride where the lead change is required by the pattern description.
12. Deduct 1/2 point for starting circle at a jog or exiting rollbacks at a jog up to two strides. Jogging beyond two strides, but less than 1/2 circle or 1/2 the length of the arena, deduct two points.
13. Deduct 1/2 point for over or under spinning up to one eighth (1/8) of a turn; deduct one (1) point for over or under spinning from one-eighth to one-fourth (1/8 to 1/4) turn.
14. A 1/2 point penalty deduction will be given for failure to remain a minimum of 20 feet (6 meters) from the wall or fence when approaching a stop and/or rollback.
15. In patterns requiring a run-around, failure to be on the correct lead when rounding the end of the arena will be penalized as follows: for 1/2 the turn or less, one (1) point; for more than 1/2 turn, two (2) points.
16. Faults against the horse to be scored accordingly, but not to cause disqualification:
- a. Opening mouth excessively when wearing bit;
  - b. Excessive jawing, opening mouth or head raising on stop;
  - c. Lack of smooth, straight stop on haunches-bouncing or sideways stop;

- d. Refusing to change leads;
  - e. Anticipating signals;
  - f. Stumbling;
  - g. Backing sideways;
  - h. Knocking over markers.
17. Faults against the rider to be scored accordingly, but not to cause disqualification:
- a. Losing stirrup;
  - b. Failure to run circles or figure eights within the markers is not considered a fault depending on arena conditions and size; however, failure to go beyond markers on rollbacks and stops is considered a fault.
18. A show may have up to three approved reining classes.
- a. If only one reining class is to be held at a show, it shall be the following:
    - i. Reining-all ages - horses 6 years old and older must be shown in bit; horses 5 years old and younger may be shown in either bit, hackamore or snaffle bit at the discretion of the exhibitor.
19. While horse is in motion, rider's hands shall be clear of horse and saddle.
20. Reining Patterns are depicted in **Attachment B**.

#### **RULE W W/J and W/T DIVISION (WESTERN / ENGLISH)**

1. Attire: See RULE E: Equipment and Attire
2. Exhibitors will be asked to walk, jog/trot in their classes.
3. All W/J and W/T exhibitors are allowed to enter all Halter Classes and Showmanship W/T Class.
4. Any W/T/J Rider who wishes to move up to the Y or B Division may do so, but will not be allowed to move back to the W/T/J Division
5. See Class list under Western and English Performance Division for rules, only exception is that you will not be asked to lope or canter. Rider will be penalized if unable to maintain the proper gait.

#### **RULE X A, B & Y WESTERN PERFORMANCE DIVISIONS**

1. Attire: See RULE E: Equipment and Attire
2. **Showmanship:** This class shall be judged strictly on the exhibitor's ability to fit and show in a halter class. A pattern will be required.
3. **Western Trail:** Classes will be judged on the performance of the horse at three gaits, performance over obstacles, response to the rider, and intelligence.
4. **All Day Western W/J:** Class to be judged on the horse both ways of the ring at the walk and jog. May be asked to back.
5. **Western Pleasure:** Class will be judge on the performance and conformation of the horse at the discretion of the judge. Entries will be penalized for incorrect gait or being on the wrong lead. Horses will be judged at a walk, jog and lope on reasonably loose rein both ways of the ring. Horses will be reversed to the inside and will be required to back.
6. **Western Horsemanship:** Riders will be judged on seat, hands and ability to control and show horse. Results as shown by performance of the horse are not to be considered more important than the method used by the rider in obtaining them. A pattern will be required.

#### **RULE Y A, B & Y ENGLISH DIVISION**

1. Attire: See RULE E: Equipment and Attire
2. **All Day English:** Class to be judged on the horse both ways of the ring at the walk and trot. May be asked to back. The smoothness, willingness and consistency of the performance will be considered.
3. **English Equitation:** Rider only is being judged. Rider will show horse at a walk, trot and canter both ways of the ring. Rider should maintain a seat that is thoroughly in balance with the horse for riding at any gait and any length of time. Should have the mount under control at all times. Demonstrate ability to be on correct lead at the canter and correct diagonals at the trot. Rider may be asked to back or any other method of proving rider's

- ability, which may include riding without stirrups, figure eight at canter on each change of lead, serpentine at a trot or canter, etc.
4. **Hunter Under Saddle:** Horses are to be shown at a walk, trot, canter and hand gallop both ways of the ring. Extended trot may be asked for by the judge. The Hunter Under Saddle should be willing, alert, responsive and move freely with a ground-covering gait. Therefore, the walk should be true and flat footed, the trot brisk and smooth, the canter collected and with the horse on the correct lead. When asked to pull up from a hand gallop, the horse should make the transition quickly and smoothly, but not so quickly that it resembles a sliding stop.
  5. **English Hunter Hack:** Horses are to be shown at a walk, trot, canter and a hand gallop both ways of the ring. Extended trot may be asked for by the judge. Horses will be required to jump 2 fences. The horse should be similar to the Hunter Under Saddle in that he is willing, alert, responsive and moves freely with a ground covering gait. His style of jumping should be smooth and consistent such as that he could be relied on to take his rider over fences in a safe, willing manner at an even hunting pace. "A" and "B" riders will jump 2'3"; "Y" riders will jump 2' and "W/T" riders not to exceed 12" on cross-rails.
  6. **English Hunter Over Fences:** Judged on manners, performance, suitability and soundness. The horse is judged over a course of fences. In show hunter classes, particular attention is paid to the horse's jumping form, the fluidity of the course, and its take-off spot for each fence on the course. The judge also looks for correct leads in the turns or clean flying changes, good movement, and a calm ride. "A" and "B" riders will jump 2'3"; "Y" riders will jump 2' and "W/T" riders not to exceed 12" on cross-rails.
  7. Hunter Over Fences Pattern is depicted in **Attachment C**.

#### **RULE Z            OPEN HALTER DIVISION**

1. Attire: See **RULE E: Equipment and Attire**. Dress code according to exhibitor's discipline.
2. **Open Halter Class:** Horses /Ponies of any breed. Horses will be led at a walk and jog. Show the horse to his advantage and keep showing until the class is dismissed.

#### **RULE AA          NON-POINTED CLASSES**

1. **Open Speed Classes: [Barrels and Poles only]** A timed event. You may W/J/L or W/T/C.
2. **Jack Pot Classes** -A total of 70% will be paid back to the exhibitors and 30% retained for the club. If five (5) entries or less, payback will be two spots: 1<sup>st</sup> Place 50%, 2<sup>nd</sup> place 20%. If more than five (5) entries, payback will be three spots; 1<sup>st</sup> Place 40%, 2<sup>nd</sup> place 20%, 3<sup>rd</sup> place 10%. Ribbons or coins will not be awarded in any Jack-Pot Class.  
**All Day Western W/J:** Class to be judged on the horse both ways of the ring at the walk and jog. May be asked to back.  
**Open English Warm Up Pleasure:** Horses will be shown at a walk/trot canter in both ways of the ring. May be asked to back. Judged on the horse only.

**Speed:** To Be Announced. Will be timed.

---

### THE DOUGLAS WEISHAAR PERPETUAL TROPHY

The Douglas Weishaar Perpetual Trophy has been presented to Lauren Weishaar by:  
The 1998 Members of the Carroll County Western Circuit.

This award will be presented to any youth (18 and under) who

- ❖ Exemplifies good sportsmanship and demonstrates a positive attitude.
- ❖ Is helpful to fellow exhibitors and club members.
- ❖ Works for the better of the club

To be eligible for this awards one must fulfill the following requirements:

- ❖ Member must be in good standing with Carroll County Western Circuit.

The above rules have been discussed and approved by:

The Board of Directors of the Carroll County Western Circuit

---

### THE WANDA FOLTZ PERPETUAL TROPHY

The Wanda Foltz Perpetual trophy has been presented to the Foltz Family by:  
Maple Grove Equine Services  
Pine Rose Farm

This trophy will be awarded to the All Around High Point Exhibitor/Owner/Horse Combination.

To be eligible for this award one must fulfill the following requirements:

- ❖ The owner and exhibitor must be in good standing with the Carroll County Western Circuit.
- ❖ The exhibitor must be signed up for points

The above rules have been discussed and approved by, Maple Grove Equine Services and Pine Rose Farm. Our wishes are that the above rules be abided by and become part of the Carroll County Western Circuit Rules and By-Laws.

- ❖ Amendment 1. The original Wanda Foltz Perpetual Trophy will remain in the possession of the Foltz Family. The Carroll County Western Circuit will have it duplicated for the purpose of passing from winning recipient to another.
- ❖ Amendment 2. Maple grove Equine Services, Pine Rose Farm and the Board of Directors of the Carroll County Western Circuit will hold the stewardship of this award.
- ❖ Amendment 3. The Foltz Family will continue to oversee any future amendments to this award as to guarantee that it maintains its integrity and does not corrupt.

Amendments 1.2 and 3 have been presented for approval on April 2, 1997 and all Governing parties have approved.

---

## GENERAL RULES

1. All classes are to be judged by the Judge except for Speed Classes.
2. The judge's decision is final.
3. At all shows, up to six placings will be given in all classes.
4. In order to qualify for Year End Awards, exhibitors 18 & older must attend 5 out of 6 shows. Exhibitors 17 & under must attend 50% of shows and complete two (2) hours of volunteer service time for Carroll County Western Circuit. Service hours are first come first served basis only and must be completed prior to the end of the show season.
5. Performance ties will be broken at Judge's discretion.
6. One hand on the reins in Western A, B & Y except when using a bosal with a full mecate. Two hands on the reins will be allowed in Leadline. Romal reins will be allowed in performance classes except when using a snaffle bit. Two hands will be allowed in all performance classes when riding a horse five (5) years or under and are using a non-mechanical hackamore, bosal or snaffle bit.
7. Chaps may be worn in all Western classes including Horsemanship.
8. Two hands are allowed in all Speed Events.
9. Spurs, bat and/or crop may be used in Speed events and jumping classes only. Excessive use of spurs, bat and/or crop may result in disqualification and removal from the show grounds. Spurs or crops are allowed in flat classes
10. **Protective headgear ASTM/SEI approved helmet with a fixed harness MUST be worn by all riders 17 & under at all times when mounted or riding. Hunting Cap of any type is mandatory for all pleasure riders over the age of 18 in all-flat classes.**
11. In the event timing devices are deemed defective, two stop watches will be used.
12. **No one will be allowed to practice barrels, pole or trail courses once they are set in the ring, unless a paid warm up round is requested.**
13. All patterns will be posted on the day of show.
14. Fences are to be free of spectators.
15. All dogs must be on a leash.
16. Children must be supervised at all times.
17. All hay and manure must be scattered and spread before leaving.
18. No glass is allowed in the Equestrian Center.
19. No horse shall enter the spectator area; concession stand and secretary's area. Horses are not allowed on the banks around the rings.
20. No horse shall be tied to any tree or fence railing.
21. The driveway entrance to the facility may not be used for parking.
22. Exhibitors with special needs or who are physically challenged and wish to visit the show are more than welcome, provided they are able to meet the gate call. Please inform the ring steward before the class you wish to show. The judge will take this into consideration when judging the class. The board members of CCWC are committed to giving each and every exhibitor a fair chance to show his/her horse.
23. Please take your trash with you.
24. Carroll County Western Circuit strives to create a Fun, Family Atmosphere. Carroll County Western Circuit **will not** tolerate unsportsmanlike conduct and violators will be asked to leave the show grounds.

If any questions arise that cannot be resolved by the use of the Carroll County Western Circuit Rule Book, we will revert to the AQHA rules and regulations.

### Canceling Due To Bad Weather

If any shows are canceled due to bad weather, the decision will be made either by 10 pm the day before or 5:30 am the day of the show and communicated to the members via email. **The weather conditions will be considered at the show grounds in Mt Airy, MD.** You may call one of the officers in the a.m.

Attachment A - Versatility Patterns

2011 Speed Patterns

Barrels

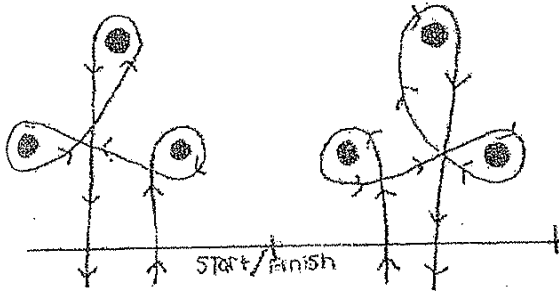
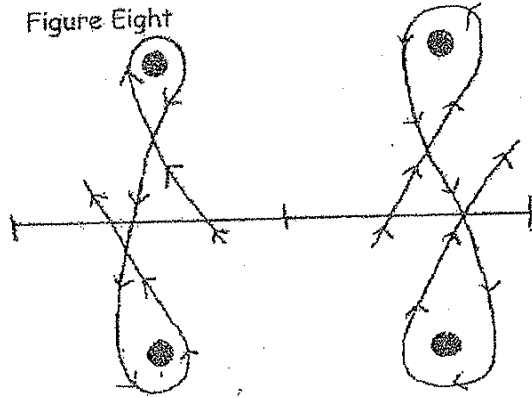

Figure Eight



Plug



Four Corners Stake Race

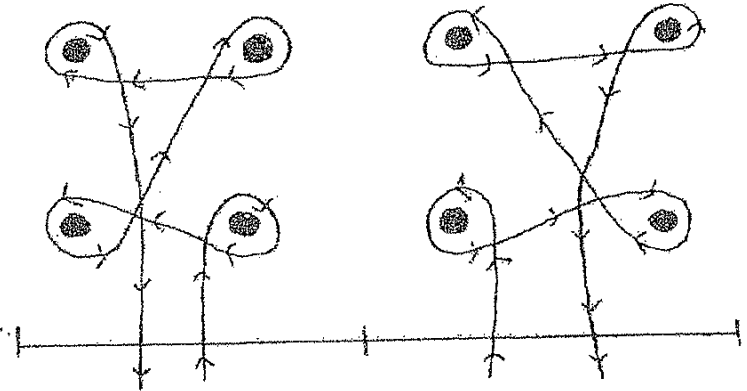

Poles

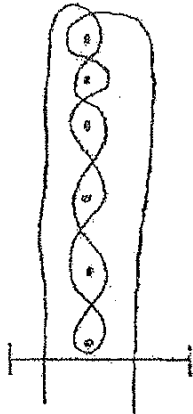

Bleeding Heart

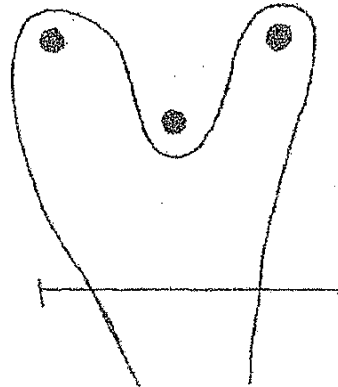

Attachment A - Versatility Patterns (cont.)

Texas Barrels

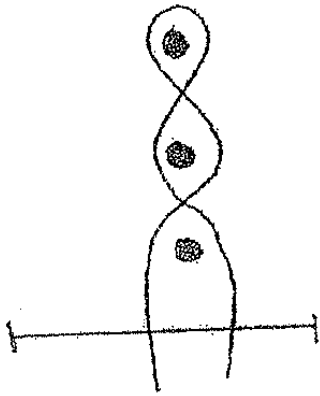

Pick-A-Lock

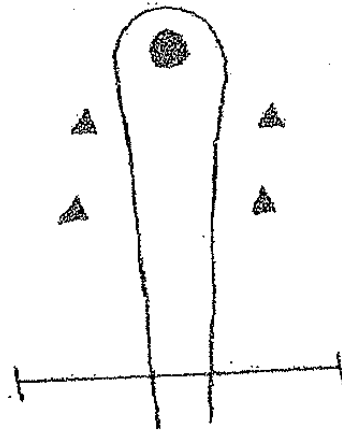

Grow As You Go

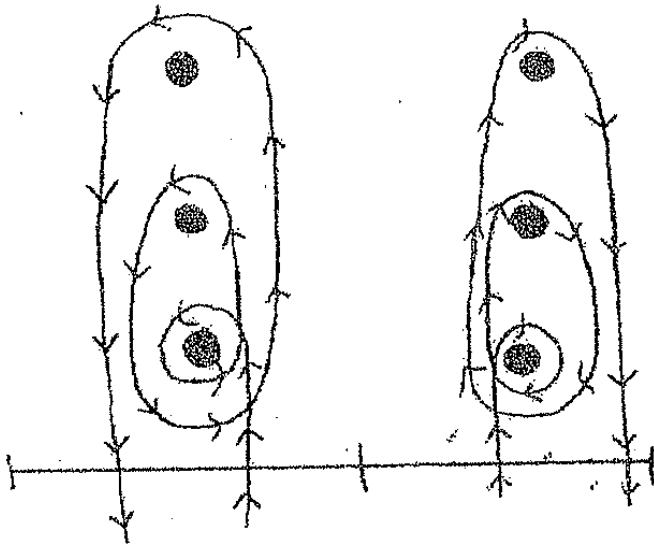

Tie Score Race

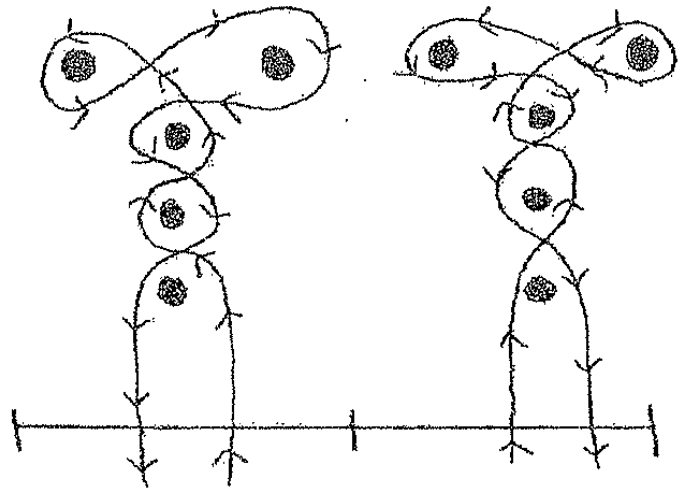

## Attachment B - Reining Patterns

### REINING PATTERN NUMBER 1

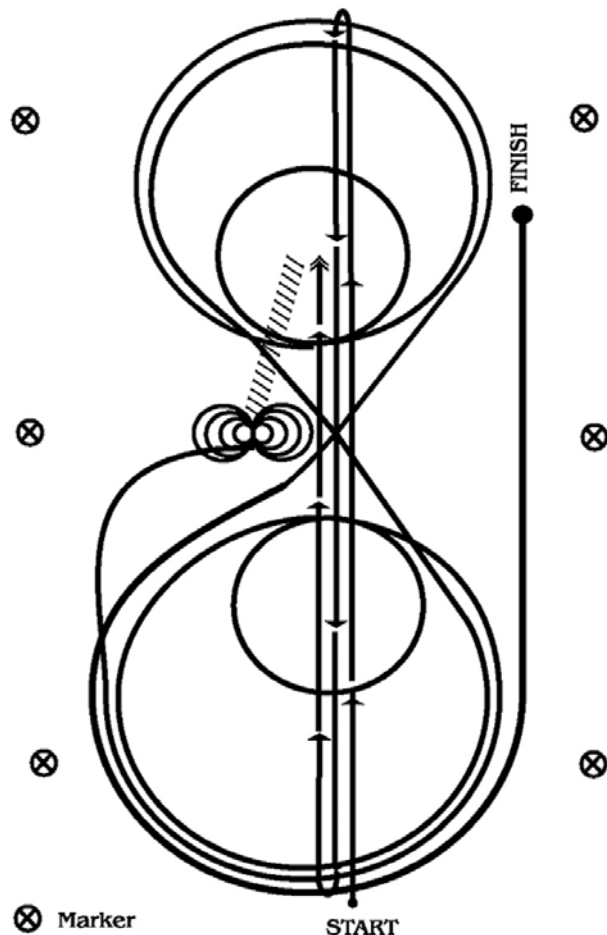

1. Run at speed to the far end of the arena past the end marker and do a left rollback - no hesitation.
2. Run to the opposite end of the arena past the end marker and do a right rollback - no hesitation.
3. Run past the center marker and do a sliding stop. Back up to center of the arena or at least ten feet (3 meters). Hesitate.
4. Complete four spins to the right.
5. Complete four and one-quarter spins to the left so that horse is facing left wall or fence. Hesitate.
6. Beginning on the left lead, complete three circles to the left: the first circle large and fast; the second circle small and slow; the third circle large and fast. Change leads at the center of the arena.
7. Complete three circles to the right: the first circle large and fast; the second circle small and slow; the third circle large and fast. Change leads at the center of the arena.
8. Begin a large fast circle to the left but do not close this circle. Run straight up the right side of the arena past the center marker and do a sliding stop at least 20 feet (6 meters) from wall or fence. Hesitate to demonstrate the completion of the pattern.

Rider may drop bridle to the designated judge.

## REINING PATTERN NUMBER 2

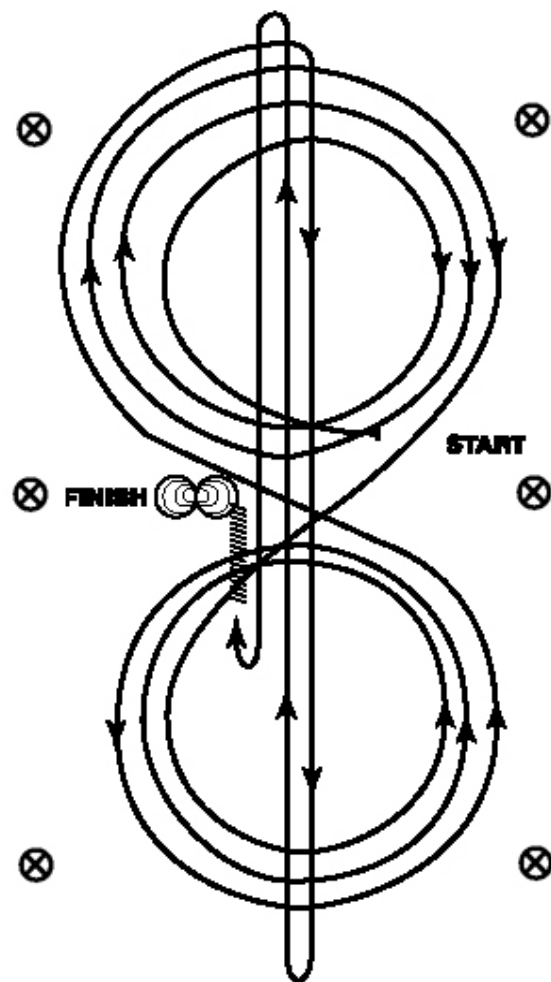

Horse must walk or stop prior to starting pattern.

Beginning at the center of the arena facing the left wall or fence.

1. Beginning on the right lead, complete three circles to the right: the first circle small and slow; the next two circles large and fast. Change leads at the center of the arena.
2. Complete three circles to the left: the first circle small and slow; the next two circles large and fast. Change leads at the center of the arena.
3. Continue around previous circle to the right. At the top of the circle, run down the middle to the far end of the arena past the end marker and do a right rollback - no hesitation.
4. Run up the middle to the opposite end of the arena past the end marker and do a left rollback - no hesitation.
5. Run past the center marker and do a sliding stop. Back up to the center of the arena or at least 10 feet (3 meters). Hesitate.
6. Complete four spins to the right.
7. Complete four spins to the left. Hesitate to demonstrate the completion of the pattern.

Rider may drop bridle to the designated judge.

## REINING PATTERN NUMBER 3

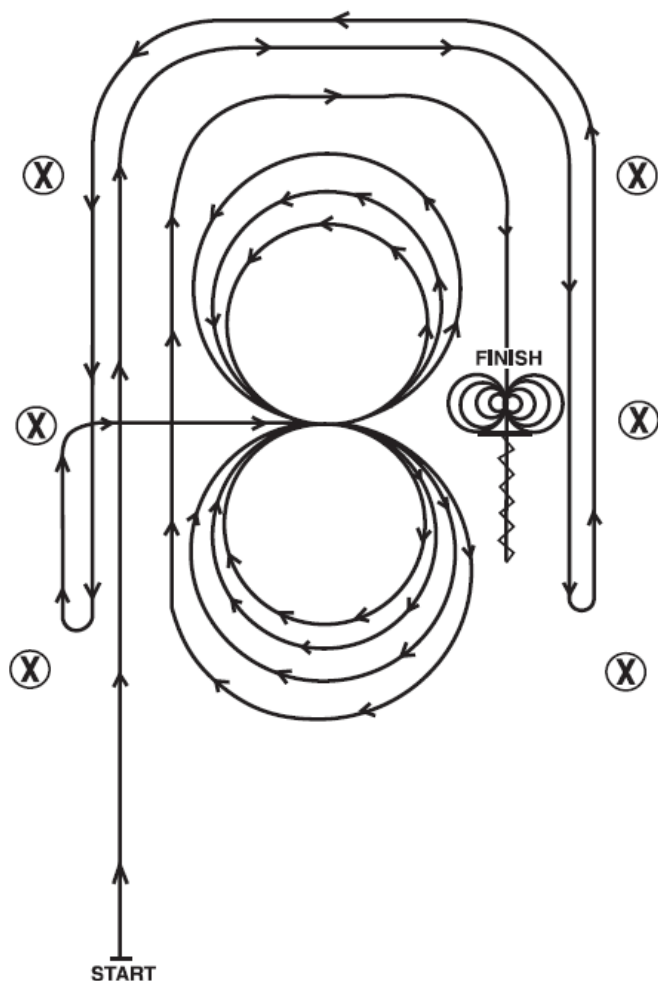

1. Beginning, and staying at least 20 feet (6 meters) from the walls or fence, lope straight up the left side of the arena, circle the top end of the arena, run straight down the opposite or right side of the arena past the center marker and do a left rollback - no hesitation.
2. Continue straight up the right side of the arena staying at least 20 feet (6 meters) from the wall or fence, circle back around the top of the arena, run straight down the left side of the arena past the center marker and do a right rollback - no hesitation.
3. Continue up the left side of the arena to the center marker. At the center marker, the horse should be on the right lead. Guide the horse to the center of the arena on the right lead and complete three circles to the right: the first two circles large and fast; the third circle small and slow. Change leads at the center of the arena.
4. Complete three circles to the left: the first two circles large and fast; the third circle small and slow. Change leads in the center of the arena.
5. Begin a large fast circle to the right but do not close this circle. Continue up the left side of the arena staying at least 20 feet (6 meters) from the wall or fence, circle the top of the arena, run straight down the opposite or right side of the arena past the center marker and do a sliding stop. Back up at least 10 feet (3 meters). Hesitate.
6. Complete four spins to the right.
7. Complete four spins to the left. Hesitate to demonstrate completion of the pattern.

Rider may drop bridle to the designated judge.

## REINING PATTERN NUMBER 4

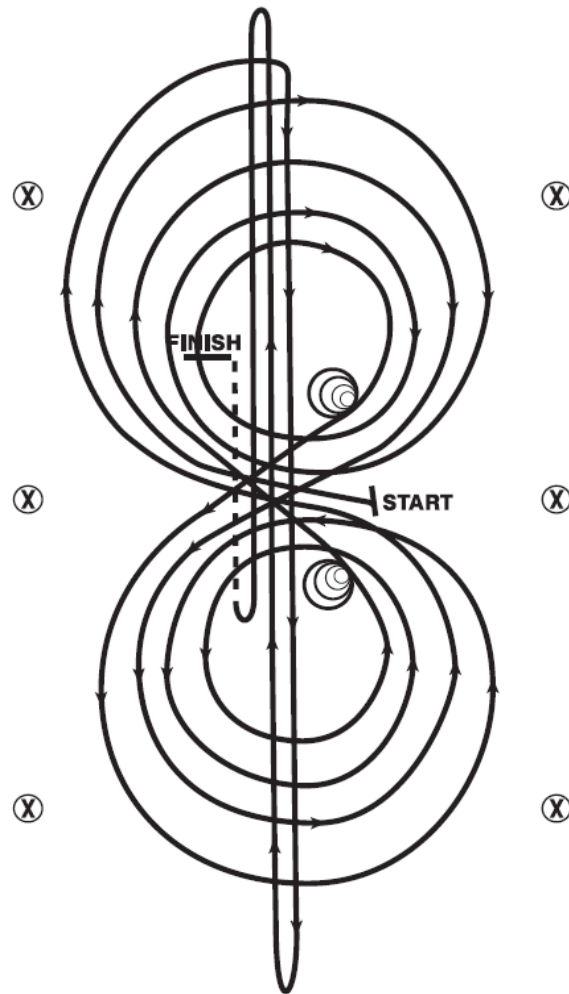

Horse must walk or stop prior to starting pattern.

Beginning at the center of the arena facing the left wall or fence.

1. Beginning on the right lead, complete three circles to the right: the first two circles large and fast; the third circle small and slow. Stop at the center of the arena.
2. Complete four spins to the right. Hesitate.
3. Beginning on the left lead, complete three circles to the left: the first two circles large and fast; the third circle small and slow. Stop at the center of the arena.
4. Complete four spins to the left. Hesitate.
5. Beginning on the right lead, run a large fast circle to the right, change leads at the center of the arena, run a large fast circle to the left, and change leads at the center of the arena.
6. Continue around previous circle to the right. At the top of the circle, run down the middle to the far end of the arena past the end marker and do a right rollback - no hesitation.
7. Run up the middle to the opposite end of the arena past the end marker and do a left rollback - no hesitation.
8. Run past the center marker and do a sliding stop. Back up to the center of the arena or at least 10 feet (3 meters). Hesitate to demonstrate completion of the pattern.

Rider may drop bridle to the designated judge.

## REINING PATTERN NUMBER 5

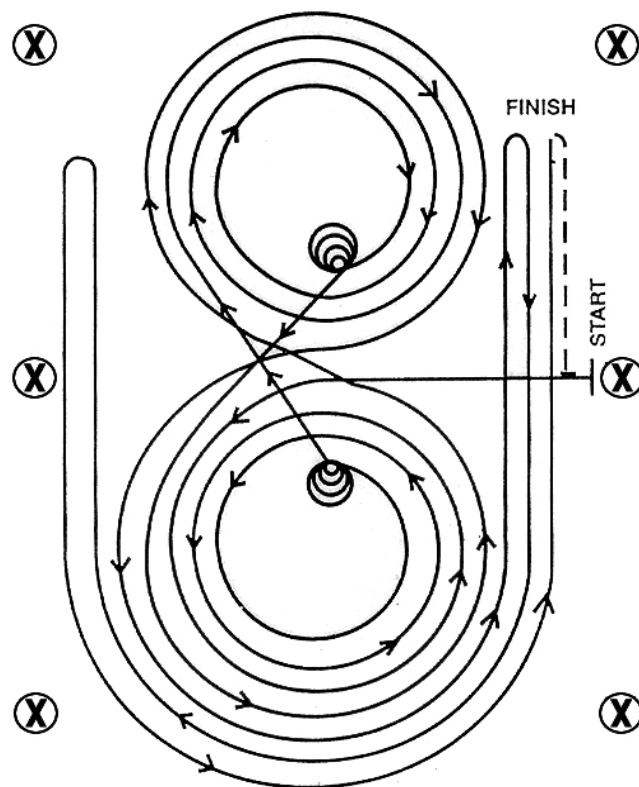

Horse must walk or stop prior to starting pattern.

Beginning at the center of the arena facing the left wall or fence.

1. Beginning on the left lead, complete three circles to the left: the first two circles large and fast; the third circle small and slow. Stop at the center of the arena.
2. Complete four spins to the left. Hesitate.
3. Beginning on the right lead, complete three circles to the right: the first two circles large and fast; the third circle small and slow. Stop at the center of the arena.
4. Complete four spins to the right. Hesitate.
5. Beginning on the left lead, run a large fast circle to the left, change leads at the center of the arena, run a large fast circle to the right, and change leads at the center of the arena. (Figure 8)
6. Continue around previous circle to the left but do not close this circle. Run up the right side of the arena past the center marker and do a right rollback at least 20 feet (6 meters) from the wall or fence - no hesitation.
7. Continue around previous circle but do not close this circle. Run up the left side of the arena past the center marker and do a left rollback at least 20 feet (6 meters) from the wall or fence - no hesitation.
8. Continue back around previous circle but do not close this circle. Run up the right side of the arena past the center marker and do a sliding stop at least 20 feet (6 meters) from the wall or fence. Back up at least 10 feet (3 meters). Hesitate to demonstrate completion of the pattern.

Rider may drop bridle to the designated judge.

## REINING PATTERN NUMBER 6

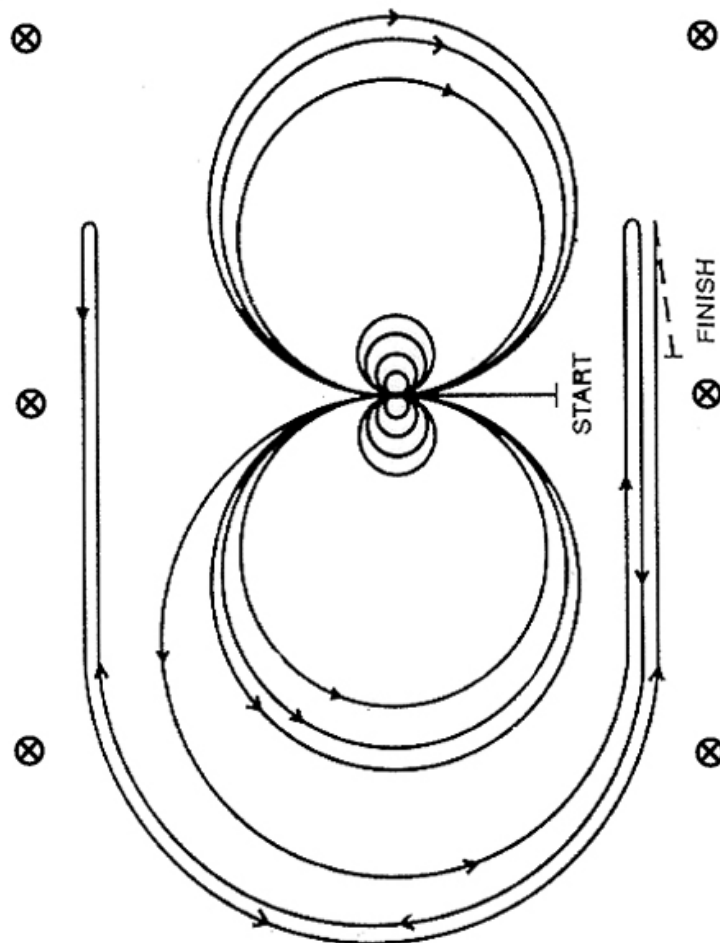

Horse must walk or stop prior to starting pattern.

Beginning at the center of the arena facing the left wall or fence.

1. Complete four spins to the right.
2. Complete four spins to the left. Hesitate.
3. Beginning on the left lead, complete three circles to the left: the first two circles large and fast; the third circle small and slow. Change leads at the center of the arena.
4. Complete three circles to the right: the first two circles large and fast; the third circle small and slow. Change leads at the center of the arena.
5. Begin a large fast circle to the left but do not close this circle. Run up the right side of the arena past the center marker and do a right rollback at least 20 feet (6 meters) from the wall or fence - no hesitation.
6. Continue back around previous circle but do not close this circle. Run up the left side of the arena past the center marker and do a left rollback at least 20 feet (6 meters) from the wall or fence - no hesitation.
7. Continue back around previous circle but do not close this circle. Run up the right side of the arena past the center marker and do a sliding stop at least 20 feet (6 meters) from the wall or fence. Back up at least 10 feet (3 meters). Hesitate to demonstrate the completion of the pattern.

Rider may drop bridle to the designated judge.

## REINING PATTERN NUMBER 7

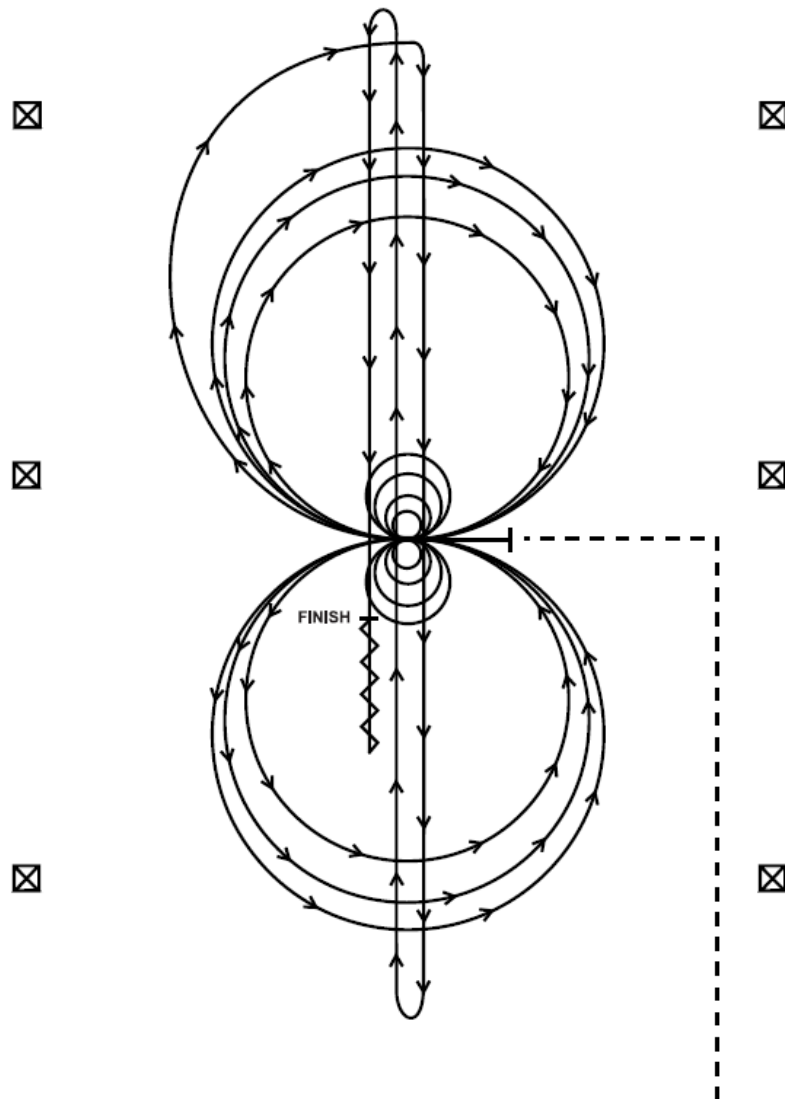

Horses must jog the majority of the way to the center. Failure to jog the majority of the way to the center will result in a 0 for failure to complete the pattern as written. Horses must walk or stop prior to starting pattern. Beginning at the center of the arena facing the left wall or fence.

1. Complete four spins to the left. Hesitate.
2. Complete four spins to the right. Hesitate.
3. Beginning on the right lead, complete three circles to the right; the first circle small and slow; the next two circles large and fast. Change leads at the center of the arena.
4. Complete three circles to the left; the first circle small and slow; the next two circles large and fast. Change leads at the center of the arena.
5. Begin a large circle to the right, but do not close this circle. Run down the center of the arena past the end marker and do a right rollback - no hesitation.
6. Run up the middle to the opposite end of the arena past the end marker and do a left rollback - no hesitation.
7. Run past the center marker and do a sliding stop. Back up to the center of the arena or at least ten feet (three meters). Hesitate to demonstrate completion of the pattern.

## REINING PATTERN NUMBER 8

Approved only for Novice Amateur, Novice Youth, and 13 and under

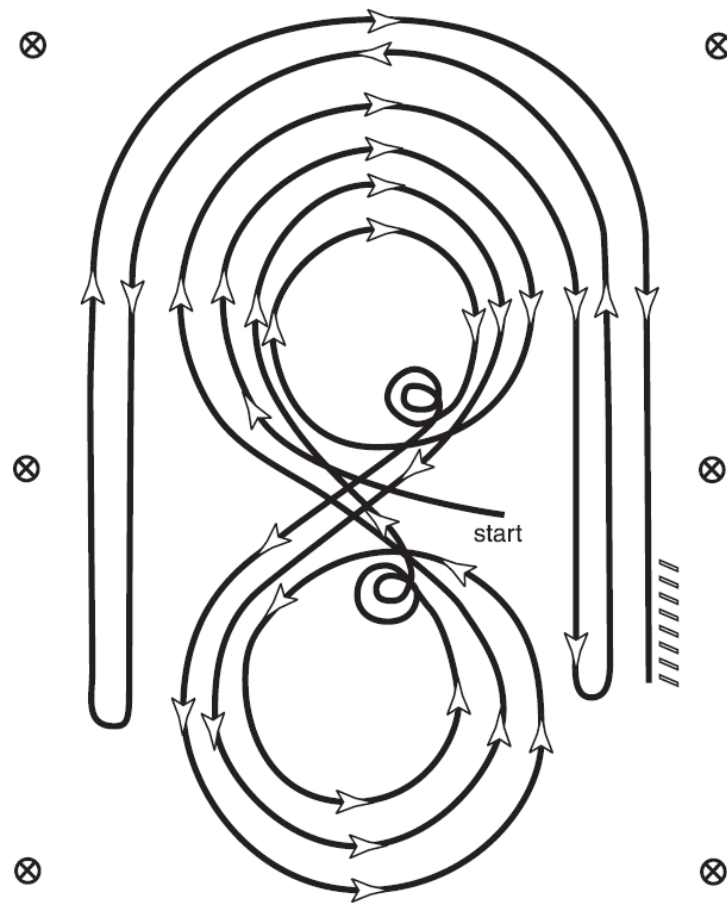

Horses must walk or stop prior to starting pattern.

1. Starting at the center marker make a large fast circle to right on the right lead.
2. Draw the circle down to a small circle until you reach the center marker; stop.
3. Do a double spin to the inside of the small circle at the center marker; at end of spins horse should be facing the left wall, slight hesitation.
4. Begin on left lead and make a large fast circle.
5. Then a small circle, again drawing it down to the center of the arena, stop, no hesitation on these stops.
6. Do a double spin to the inside of the circle, slight hesitation, horse to be facing left wall.
7. Take a right lead and make a fast figure eight over the large circles, close the eight, and change leads.
8. Begin a large fast circle to the right but do not close this circle. Run down the right side of the arena past the marker and do a left roll back at least 20 feet (6 meters) from the wall or fence - no hesitation.
9. Continue back around the previous circle but do not close this circle. Run down the left side of the arena past the center and do a right roll back at least 20 feet (6 meters) from the wall or fence - no hesitation
10. Continue back around previous circle but do not close this circle. Run down the right side of the arena past the center marker and do a sliding stop at least 20 feet (6 meters) from the wall or fence. Back up at least 10 feet (3 meters). Hesitate to show completion of pattern.

Rider may drop bridle to the designated judge.

Attachment C - English Pattern

Hunter Over Fences

